



# SIMON BULKHEAD LIGHT

**WARNING** Never take risks with electrical safety. Always disconnect the mains power before beginning any electrical work and test that it is isolated - it is NOT enough just to turn off the light switch. Electrical products must be installed in accordance with IET regulations (BS 7671). If you are in any doubt, always consult a qualified electrician or an experienced person registered with an electrical Competent Person Scheme. Further information is available online or from your Local Authority. If the lighting circuit is not protected by a Residual Current Device (RCD) then the installation should be carried out and tested by a qualified electrician. If necessary, use a suitable stepladder, but first read the useful advice given by the Health and Safety Executive. Visit [www.hse.gov.uk](http://www.hse.gov.uk) and search for 'using stepladders'.

In addition to the contents of this kit, you will need:

- Lamp 60W max. with ES (Edison Screw) fitting
- Suitable 3-core power cable with a circular profile and an outside diameter of 7mm (to ensure a good watertight seal through the cable gland). The cable should be outdoor rated. Twin & Earth cable is not suitable.
- Temperature resistant cable sleeving.
- Appropriate tools and fixings

## Your bulkhead light

Your bulkhead light is suitable for outdoor use. Ensure the cable gland forms a tight seal around the cable. The ideal cable for the job will be outdoor rated, circular in profile and have an overall outside diameter of 7mm - any thicker and it may not pass through the rubber o-ring inside the gland; any thinner and a watertight seal may not be fully formed.

**IMPORTANT:** If you are in any doubt, STOP and seek professional help. Do not proceed unless you are sure.

Unscrew the upper lightcage assembly (anti-clockwise when viewed from above) from the lower base. Use two appropriate screws/bolts to mount the base onto the required surface.

Inside the base, remove the two screws that secure the lamp holder and connect the power cable as shown right - the earth wire must be connected to the screw terminal inside the lower base. Ensure that there is a little slack cable inside. Fit temperature resistant sleeving to each wire to protect them from the heat of the lamp. Check that the live wire is connected to the centre pin of the lamp holder.

Replace the lamp holder onto its two pillars and the two holding screws. Tighten the cable gland so that it grips the cable and forms a watertight seal.

Once the wiring is complete and the lamp installed, replace the upper lightcage assembly and screw it tight (clockwise when viewed from above).

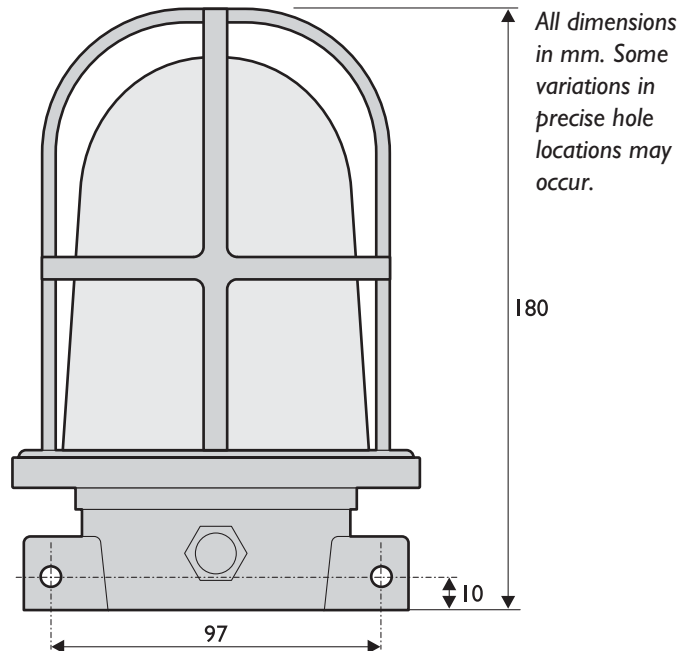

To prevent water ingress, install in the direction illustrated.

