



CONDUIT CEILING ROSE

WARNING Never take risks with electrical safety. Always disconnect the mains power before beginning any electrical work and test that it is isolated - it is NOT enough just to turn off the light switch. Electrical products must be installed in accordance with IET regulations (BS 7671). If you are in any doubt, always consult a qualified electrician or an experienced person registered with an electrical Competent Person Scheme. Further information is available online or from your Local Authority. If the lighting circuit is not protected by a Residual Current Device (RCD) then the installation should be carried out and tested by a qualified electrician. If necessary, use a suitable stepladder, but first read the useful advice given by the Health and Safety Executive. Visit www.hse.gov.uk and search for 'using stepladders'.

In addition to the contents of this kit, you will need:

- Lighting cable*, lamps and holders
- Connectors
- Appropriate tools

* Your lighting cables must have a minimum conductor cross sectional area of 0.5mm² and a temperature rating of 85°C. Please visit www.dowsingandreynolds.com for options. Avoid using heavy lamp shades with this rose.

Your existing connections

Your existing domestic lighting circuit is most likely to use a *Loop-in (aka Radial)* system where the mains supply is passed from one room to another. Depending on your installation, the loop connections will either be located in each ceiling rose or (in older properties) within each switch. The typical arrangement you are likely to find within a ceiling rose is shown right ➤

Note: Depending on how your property is wired, you may need to purchase additional 'maintenance free junction boxes', please see the note overleaf or contact Dowsing & Reynolds for details.

You will need to disconnect the existing wiring and remove the existing ceiling rose. So your first step, after isolating the power for the lighting circuit at your fuse board (and double-checking that it's dead), should be to take clear photo records of the open ceiling rose. Then, you need to identify and clearly label each of the cable groups. Clues to look for:

- The blue (or black) wire coming back from the switch should have a brown (or red) coloured sleeve on it - to identify that it carries a switched live feed. *Note: If a sleeve is not present, you should fit one once you identify the correct wire.*
- That marked wire from the switch will connect only with the wire(s) leading to the lamp(s).
- Using the above two clues, you should be able to identify the *Switch* and *Lamp* cable groups. The remaining cable group(s) will be the mains *feed in* and, if present, *feed out*. You don't need to know which is *in* and which is *out* for this task, just that they are the feed cables.

IMPORTANT: If you are in any doubt, STOP and seek professional help. Do not proceed unless you are sure.

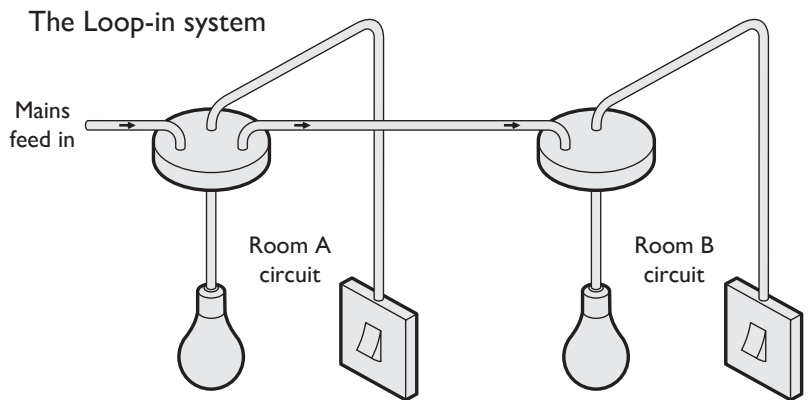

A typical ceiling rose

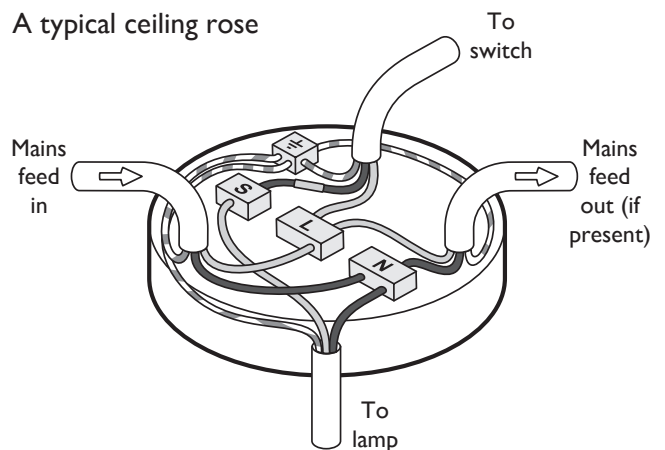

Connection	Old wire colours	New wire colours	Diagram shading
Live (L)	Red	Brown	
Neutral (N)	Black	Blue	
Earth (⊕)	Green	Green/Yellow	

Note: Our ceiling roses are designed to compliment a range of decors, from traditional to contemporary. Due to the delicate proportions of certain ceiling roses, there is limited space inside for connections. We supply three 3-way Wago® connectors with each single outlet rose and three 5-way Wago® connectors with each three outlet rose (shown right). However, there may not be sufficient space to recreate a full set of loop (aka Radial) connections within the rose. In which case these would need to be housed elsewhere, with only the final 3 core lamp cable connections being made inside, or near to, the ceiling rose. If connections are to be moved into the ceiling cavity it is essential that you enclose them within an approved 'Maintenance free junction box'. These are available from Dowsing and Reynolds or other electrical suppliers.

Supplied with each rose:

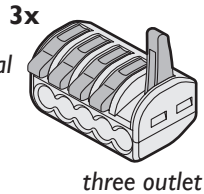
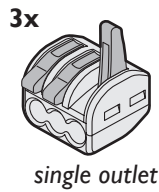

Fitting your new conduit ceiling rose

- 1 Follow all of the instructions given overleaf.
- 2 Use a tester to ensure power has been completely isolated.
- 3 Disconnect the wires from the original rose.
- 4 Remove the original rose from the ceiling.
- 5 Determine where the new rose cup can be screwed into the ceiling. It is important that the screws are driven into the wooden beam above the ceiling surface. It is also vitally important that they do not disrupt any cabling in the ceiling space. Take time to properly survey the location.

Note: Alternative rose cups are available for conduit connections:

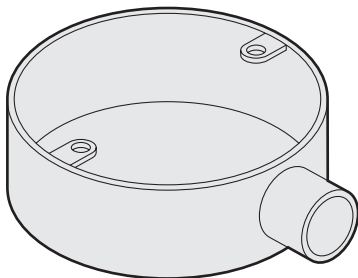

Single entry conduit rose cup

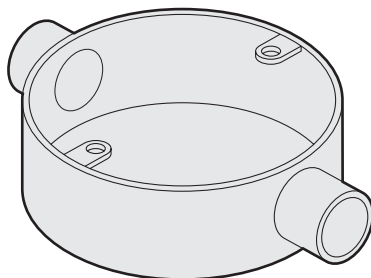

Dual entry conduit rose cup

- 6 Insert the various cables into your new ceiling rose cup such that there are sufficient lengths within the rose interior (plus a little extra) to make the connections.

Note: It's generally a good idea to leave some extra length on the cable drop and to not attach the lamp holder until the rose is in fully place; whereupon the length can be determined exactly.

- 7 Two screws are supplied with your kit; check that they are suitable for the mounting location and, if so, insert them through the two smaller holes in the rose base and into the beam above the ceiling to secure.
- 8 Make the necessary connections with the feed cables entering the rose.
 - If access above the ceiling space is possible, use a maintenance free junction box and distribute the connections up there.
 - The rose cup is metallic, so ensure that a valid CPC (Circuit Protective Conductor) earth connection is also made to the rose earthing point located on the centre cable clamp.
 - If a double insulated (class 2) light fitting (denoted by the logo) is used, then it is not necessary to make an earth connection to the cable drop(s).
- 9 Once all connections have been made and double checked, raise the cover plate up to the rose cup so that the screw holes align with the threaded lugs in the cup. Insert and tighten the two screws to secure it in place.
- 10 Fit your chosen lamp holder(s) to the cable drop(s), insert the lamp(s) and restore power to the circuit.

