



MODULAR PANELS

WARNING Never take risks with electrical safety. Always disconnect the mains power before beginning any electrical work and test that it is isolated - it is NOT enough just to turn off the light switch. Electrical products must be installed in accordance with IET regulations (BS 7671). If you are in any doubt, always consult a qualified electrician or an experienced person registered with an electrical Competent Person Scheme. Further information is available online or from your Local Authority. If the lighting circuit is not protected by a Residual Current Device (RCD) then the installation should be carried out and tested by a qualified electrician. If necessary, use a suitable stepladder, but first read the useful advice given by the Health and Safety Executive. Visit www.hse.gov.uk and search for 'using stepladders'.

Our modular panels are available in single gang and double gang sizes with a variety of module types. Two versions of the single gang panels can accommodate either one half-size or one full-size module respectively, whereas all double gang panels can hold either two full-size modules or one full-size plus two half-size, or four half-size modules.

Note: Where mains connections are made, this product must be installed in accordance with local building regulations.

IMPORTANT: If you are in any doubt, STOP and seek professional help. Do not proceed unless you are sure.

To fit your panel

- 1 Ensure that the mains supply to the wall circuit is isolated.
- 2 With a small flat blade screwdriver, carefully lever off the front cover from the panel. There are two slots on the underside lip of the front cover.
- 3 Insert your chosen modules into the panel. Small clips, top and bottom, will lock each module into place.
- 4 Connect your modules to their respective cabling. Please see overleaf for connection details.
- 5 If mains power is being used on the panel, ensure that a protective earth connection is also made to the earth terminal on the panel.
- 6 Once all modules are in place and connected, use the two supplied screws to fix the panel in place on the wall box.
- 7 Finally, ensure the two slots of the front cover are facing downwards and fit the front cover to the panel so that it clips into securely into place, concealing the fixing screws.

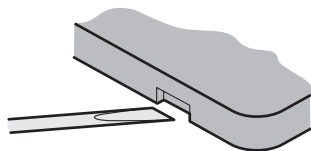

- 3 Insert your chosen modules into the panel. Small clips, top and bottom, will lock each module into place.
 - 4 Connect your modules to their respective cabling. Please see overleaf for connection details.
- IMPORTANT:** Ensure that cabling from one module cannot come into contact with anything in a neighbouring module, particularly when mains power is involved.

- 5 If mains power is being used on the panel, ensure that a protective earth connection is also made to the earth terminal on the panel.

NOTE: If you're fitting a brush plate, an earthed connection is not necessary.

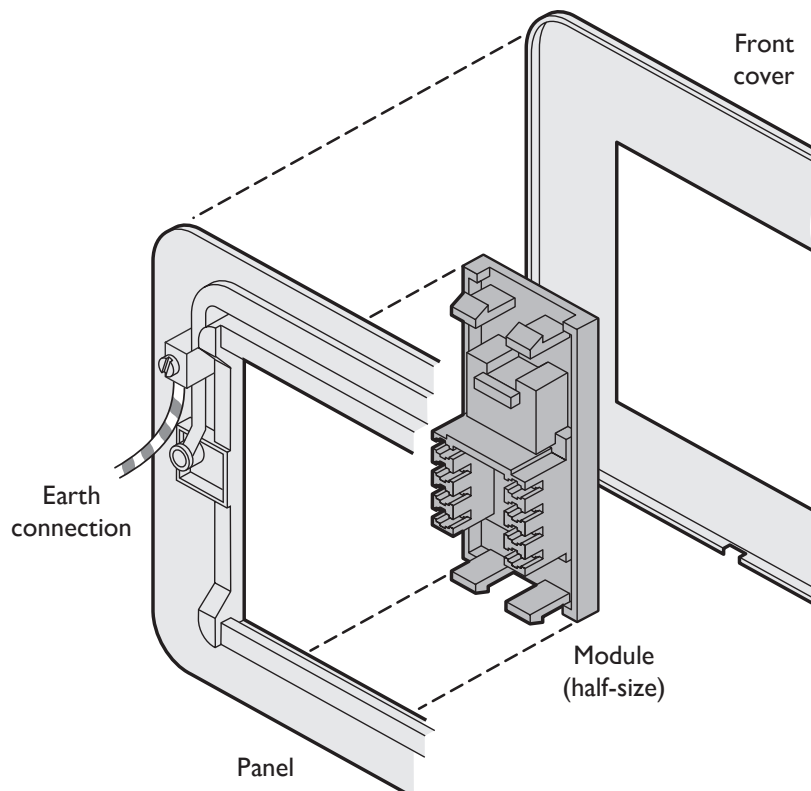

Schuko power module

The live and neutral connections can be made either way round to the two main terminals.

This module must be given a valid protective earth connection to the terminal labelled .

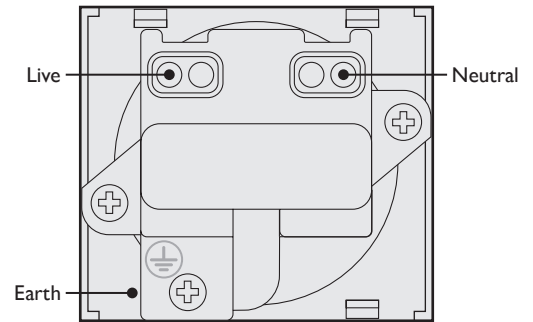

USB power module

Connect the Live and Neutral of the AC power input (115-230V) to the two labelled terminals.

No protective earth connection is possible with this module.

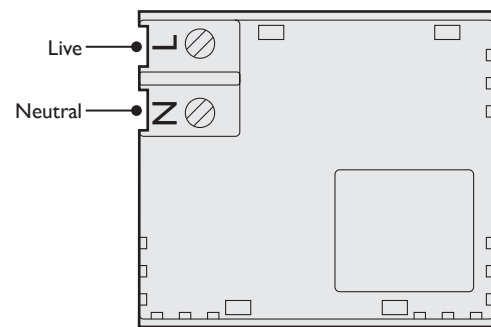

UK telephone extension module

Use only solid-conductor twisted-pair type cables: CAT5e network cable is fine, or otherwise use CW1308 telephone cable (2 pairs are sufficient). You will also need a suitable punch down tool to insert the wires into the socket terminals.

Only three wires are actually used. Connect three wires to the numbered terminals on the BT master socket as follows: 2-Blue, 3-Orange and 5-White/Blue. *Note: CAT5e cable uses Blue/White and Orange/White colours.* At this module, connect those same three wire colours to the terminals shown. Coil the unused wires safely away from any of the terminals and any other wires within the panel.

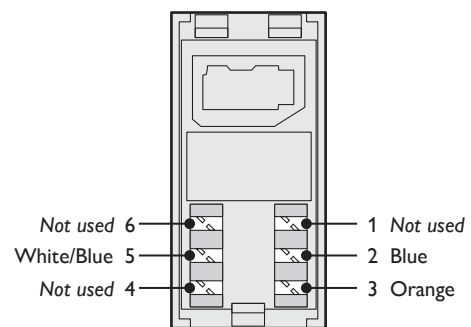

TV aerial and satellite dish modules

TV and satellite connections require coaxial cable, many types are available; we recommend using WF100 specification cable for both terrestrial TV (UHF) and satellite links.

You need to strip away the outer sleeve to expose the braided screen - this will be held by the clamp part of the socket. The inner insulation should extend beyond the braid and you need to ensure that none of the braid strands go anywhere near the exposed core conductor or its connection to the socket. Clamp the core conductor using the screw terminal.

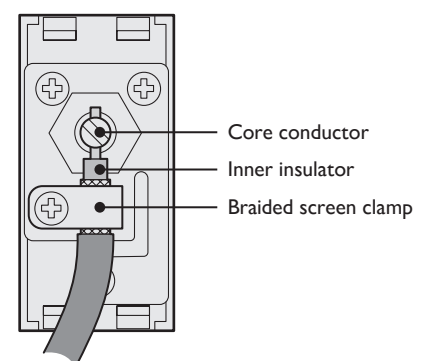

Network module

Use only solid-conductor twisted-pair type cables: CAT5e or CAT6. You will also need a suitable punch down tool to insert the wires into the socket terminals.

Please consult your electrician to wire up the module appropriately for your destination, depending on whether the item will be through wired or cross wired using the guides on the module as reference.