



PENDANT LIGHT

WARNING Never take risks with electrical safety. Always disconnect the mains power before beginning any electrical work and test that it is isolated - it is NOT enough just to turn off the light switch. Electrical products must be installed in accordance with IET regulations (BS 7671). If you are in any doubt, always consult a qualified electrician or an experienced person registered with an electrical Competent Person Scheme. Further information is available online or from your Local Authority. If the lighting circuit is not protected by a Residual Current Device (RCD) then the installation should be carried out and tested by a qualified electrician. If necessary, use a suitable stepladder, but first read the useful advice given by the Health and Safety Executive. Visit www.hse.gov.uk and search for 'using stepladders'.

In addition to the contents of this kit, you will need:

- Lamp with ES (Edison Screw) fitting
- (Optional) Additional Wago® connectors for loop connections.
- Appropriate tools

Before you start anything, please make a cup of tea and read these instructions fully. If you are in any doubt, STOP and seek professional help. Do not proceed unless you are sure.

Your existing connections

Your existing domestic lighting circuit is most likely to use a *Loop-in (aka Radial)* system where the mains supply is passed from one ceiling rose to the next; with the switches and lights for each room emanating from those same roses.

Note: Some older properties may alternatively loop into and out of the switches rather than the roses. The typical arrangement you are likely to find within your ceiling rose is shown right ➤

You will need to disconnect the existing wiring and remove the existing ceiling rose. So your first step, after isolating the power for the lighting circuit at your fuse board (and double-checking that it's dead), should be to take clear photo records of the open ceiling rose. Then, you need to identify and clearly label each of the cable groups. Clues to look for:

- The blue (or black) wire coming back from the switch should have a brown (or red) coloured sleeve on it - to identify that it carries a switched live feed. *Note: If a sleeve is not present, you should fit one once you identify the correct wire.*
- That marked wire from the switch will connect only with the wire(s) leading to the lamp(s).
- Using the above two clues, you should be able to identify the *Switch* and *Lamp* cable groups. The remaining cable group(s) will be the *mains feed in* and, if present, *feed out*. You don't need to know which is *in* and which is *out* for this task, just that they are the feed cables.

Note: This product must be installed in accordance with local building regulations.

The Loop-in system

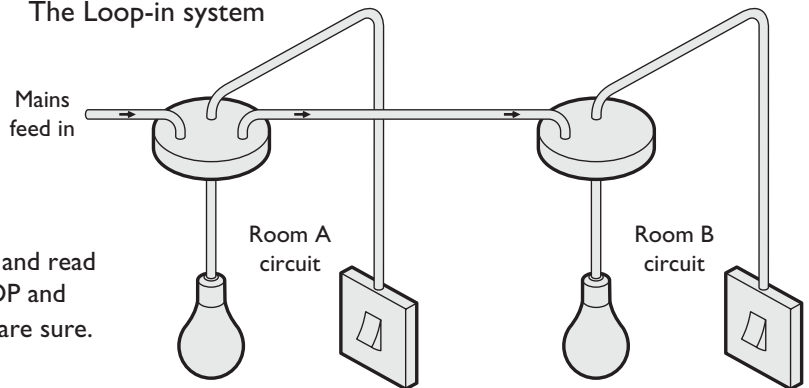

A typical ceiling rose

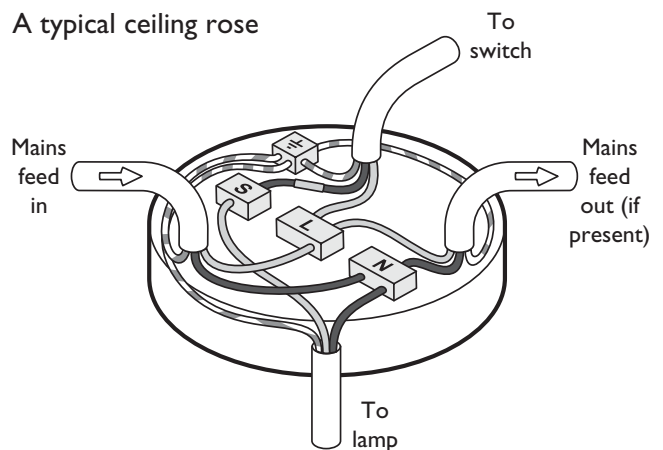

Connection	Old wire colours	New wire colours	Diagram shading
Live (L)	Red	Brown	
Neutral (N)	Black	Blue	
Earth (⊕)	Green	Green/Yellow	

Note: Your ceiling rose kit is not suitable for use in circuits with ratings that exceed 10 Amps.

Fitting your new pendant ceiling rose

Note: The connector block supplied within the rose is designed for a simple end-point power connection. If you need to recreate a loop-in arrangement, you will need replacement connectors, such as Wago® 221-413, available from www.dowsingandreynolds.com

- 1 Follow all of the instructions given overleaf.
- 2 Shut off power to the circuit and use a tester to ensure power has been completely isolated.
- 3 Disconnect the wires from the original rose.
- 4 Remove the original rose from the ceiling.
- 5 Determine where the mounting bracket for the new rose can be screwed into the ceiling. It is important that the screws are driven into the wooden beam above the ceiling surface. It is also vitally important that they do not disrupt any cabling in the ceiling space. Take time to properly survey the location. It may be necessary to install a further mounting point (known as a *Noggin*) for the bracket (if it is wider than the original rose) by accessing the floor above.
- 6 Check that the supplied screws are suitable for the mounting location and, if so, insert them through the tabs in the rose ring and into the beam above the ceiling to secure. *Note: For concrete/masonry type surfaces, also use the supplied wall plugs.*
- 7 For loop-in connections, skip to step 8.

For simple end-point connections, open the supplied connector block and secure the incoming live, neutral and earth wires to the terminals as shown right (then reseal the block and skip to step 9):

- 8 For loop-in connections: Remove the supplied connector block. Using the labelled cables as discussed overleaf, you now need to recreate the loop-in circuit links that existed in the original rose, using suitable connectors (that are rated and insulated for 240VAC use) - we recommend Wago® terminal blocks (part number 221-413) which are available from www.dowsingandreynolds.com. You will need four of these connectors to form the live, neutral, switched and earth connection groups.

Be aware that there is limited room within the rose and numerous connections to be made. Plan your layout carefully.

Notes:

- If access above the ceiling space is possible, another method is to use a sealed junction box and distribute the connections up there.
- A valid CPC (Circuit Protective Conductor) earth connection must be supplied by the existing supply cable to the rose.
- Ensure that the bare copper earth connections have green/yellow sleeves to isolate them from other connections.

- 9 The rose ring is metallic, so ensure that a valid earth connection is also made to the rose earthing point located on the centre cable clamp.
- 10 Once all connections have been made and double checked, align the two holes of the cover plate with the two threaded tabs in the ring. Insert and tighten the two screws (using the supplied 2.5mm hex key) to secure it in place.
- 11 If necessary, fit the shade to the lamp holder, insert a lamps and restore power to the circuit.

IMPORTANT: If the external flexible cable of this luminaire becomes damaged, it shall be exclusively replaced by the manufacturer or his service agent or a similar qualified person in order to avoid a hazard.

