



# Escutcheons and Thumb Locks

**IMPORTANT:** If you are in any doubt, STOP and seek professional help. Do not proceed unless you are sure.

## Your escutcheon plates / thumb locks

Your escutcheon plates / thumb locks are designed for interior applications only and are available in various designs.

### To fit your escutcheon plates / thumb locks

1. If not already fitted, mount your chosen lock mechanism into the door using the instructions provided by the manufacturer. See opposite for the required spindle size.
2. Separate the front cover from the hidden inner frame. The two styles of plate have different ways to separate the two parts:

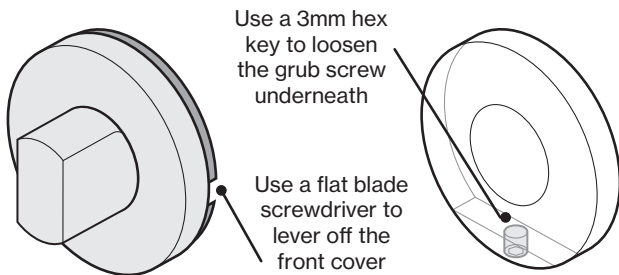

3. Offer up the inner frame to the position it will take on your door. Ensure that the inner frame is centred exactly around where the spindle/lock is (or will be).
4. Mark the mounting holes that you will use; one style of inner frames have two holes, the other type has six holes (but you will not need to use all of them).
5. Carefully drill small pilot holes for the screws and mount the inner frame in place using the supplied screws.
6. Repeat for the other side of the door.
7. Push the spindle through the lock barrel. For narrow doors you can shorten the spindle by sawing off the excess with a hacksaw (also use a file to smooth off any sharp burrs that result from the cut).
8. Fit the chosen escutcheon plates / thumb locks to the frames mounted on each side of the spindle and secure them. Depending on the style, either push the plate onto the inner frame until it wedges into place, or use the hex key to tighten the grub screw located underneath.

This type of inner frame has six mounting holes (you don't need to use them all) and the thumb lock is designed to accept a 6mm square spindle.

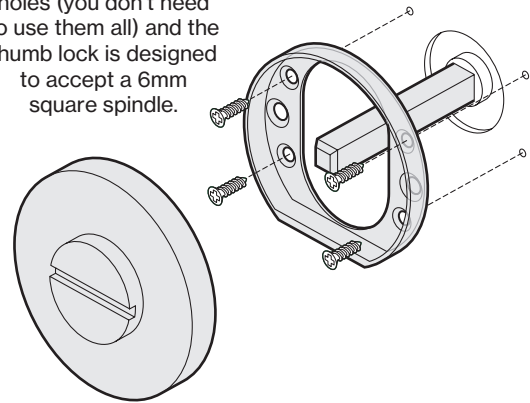

This type of inner frame has two mounting holes and the thumb lock is designed to accept a 5mm square spindle.

