



Solenne Alabaster Tube Wall Light

WARNING Never take risks with electrical safety. Always disconnect the mains power before beginning any electrical work and test that it is isolated - it is NOT enough just to turn off the light switch. Electrical products must be installed in accordance with IET regulations (BS 7671). If you are in any doubt, always consult a qualified electrician or an experienced person registered with an electrical Competent Person Scheme. Further information is available online or from your Local Authority. If the lighting circuit is not protected by a Residual Current Device (RCD) then the installation should be carried out and tested by a qualified electrician. If necessary, use a suitable stepladder, but first read the useful advice given by the Health and Safety Executive. Visit www.hse.gov.uk and search for 'using stepladders'.

Before you start anything, please make a cup of tea and read these instructions fully. If you are in any doubt, STOP and seek professional help. Do not proceed unless you are sure. This product must be installed in accordance with local building regulations.

To fit your Tube wall light

- 1 Shut off power to the circuit and use a tester to ensure power has been completely isolated.

Note: These lights are not suitable for use in circuits with ratings that exceed 10 Amps.

- 2 Using a Pozi-Drive/Philips screwdriver, remove the screw located at the top of your tube light and separate the rear mount bracket from the main body.

- 3 Offer up the rear mount bracket to the position on the wall where you'd like to mount the light.

It is vitally important that the screws do not disrupt any cabling behind the wall surface. Take time to properly survey the location.

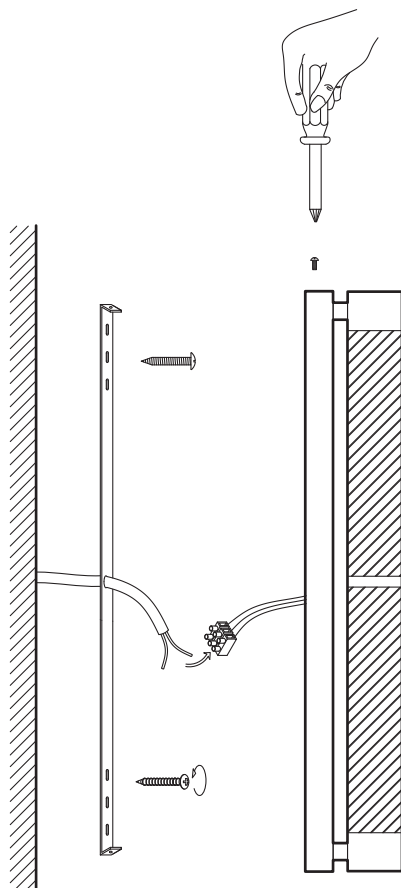

- 4 When you have checked for the location of any cables or pipes in the wall, mark two points through the rear mount bracket.

- 5 For brick walls: Use a drill and an 8mm masonry drill bit to create two holes at your mark points. Then insert the two supplied wall plugs.

For wooden mount points: Use a drill and a 2mm wood drill bit to create two shallow pilot holes at your mark points.

- 6 Place the rear mount bracket over the holes and feed the incoming mains lighting feed cable through the hole in the centre. Insert and tighten the two supplied screws to secure the rear mount bracket.

- 7 Carefully strip the outer sheath and individual wires of the incoming feed - the bare wire tips should have an exposed length of roughly 7mm. For twin and earth cables, place a suitable length of green/yellow insulation tubing over the bare earth wire so that only 7mm of the tip is exposed.

- 8 Connect the **Live** (Brown or Red), the **Neutral** (Blue or Black) and the **Earth** (Green/Yellow or just Green) to the corresponding coloured wires of the conn block. Double check all connections.

- 9 Carefully replace the main body onto the rear mount bracket and replace the screw that you removed earlier.

- 10 Restore power to the circuit and switch on the light.